

1 2 3 4 5 6 7 8

A
B
C
D
E
F

A
B
C
D
E
F

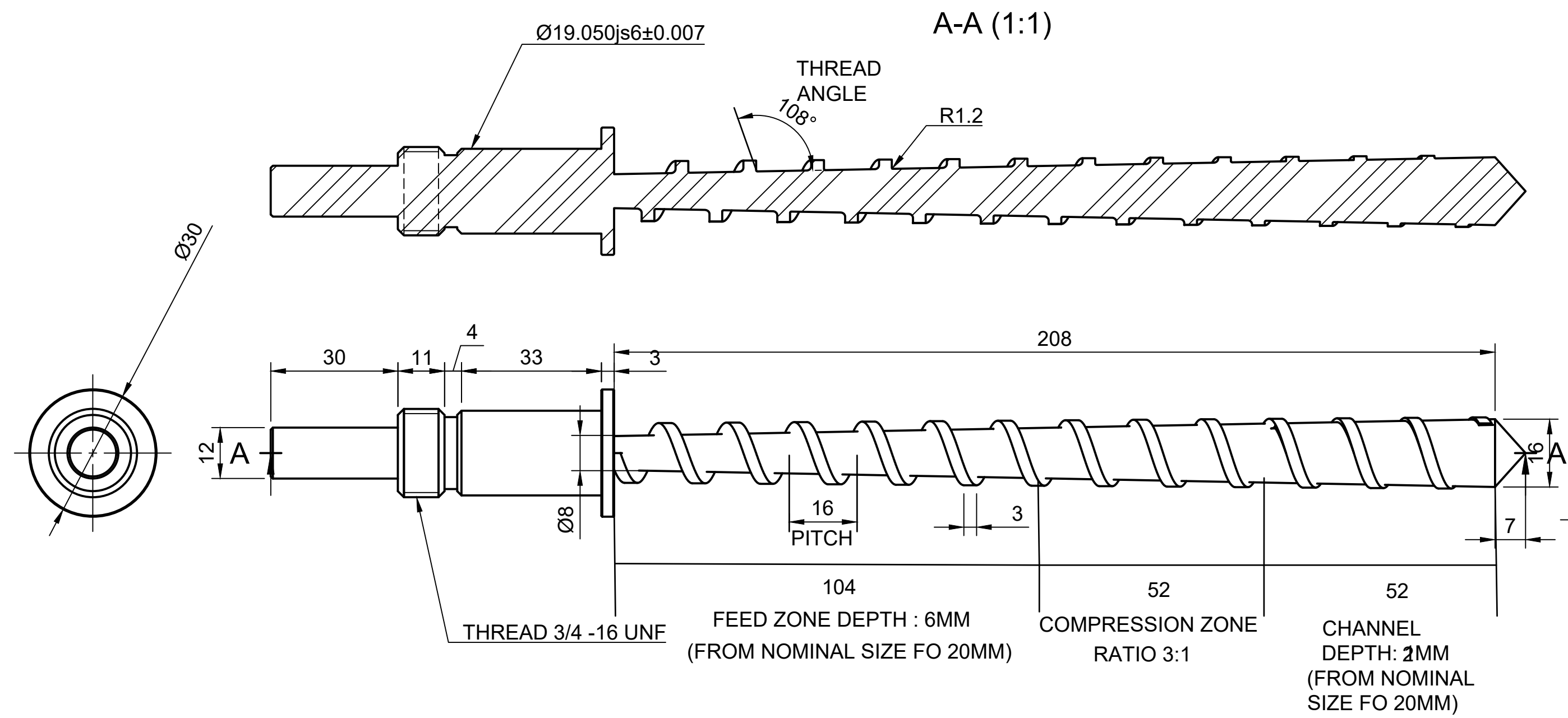

NOTE:

THE THREAD SHOULD BE HAVE Ø19MM DIA TO BE FREE TO ROTATE IN Ø20MM INNER DIA PIPE.

ALL DIMENSIONS ARE IN MM

Dept.	Technical reference	Created by uday oleti	07-Dec-20	Approved by
MATERIAL: STEEL		Document type		Document status SCALE: 1:1
		Title Extruder Screw		DWG No. 4
		Rev.	Date of issue	Sheet 1/1

1 2 3 4 5 6 7 8